

<b>Engine</b>	Shangchai SC4H140.2G2
<b>Rated Power</b>	103 kW (138 hp) @ 2,000 rpm
<b>Nominal Amplitude Range</b>	2.0 / 1.2 mm
<b>Vibration Frequency Range</b>	30 Hz
<b>Centrifugal Force Range</b>	280 / 170 kN
<b>Working Width</b>	2,130 mm
<b>Operating Mass</b>	14,000 kg

# 6114E ROLLER

 **LIUGONG**



TOUGH WORLD. TOUGH EQUIPMENT.

# 6114E SPECIFICATIONS >>>

ENGINE	
Emission Regulation	Tier 2 / Stage II
Make	Shangchai
Model	SC4H140.2G2
Rated Power	103 kW (138 hp) @ 2,000 rpm
Peak Torque	535 N·m
Number of Cylinders	4
Aspiration	Turbocharged
Cooling Type	Water

ELECTRICAL SYSTEM	
System Voltage	24 V

DRIVE TRAIN	
Theoretical Gradeability	30 %
Transmission Type	Mechanical
1st Maximum Speed, Fwd	2.7 km/h
2nd Maximum Speed, Fwd	5.2 km/h
3rd Maximum Speed, Fwd	11 km/h
Min. Outside Turning Radius	6,500 mm

AXLES	
Steering System	Hydraulic
Steering Method	Articulation
Steering Angle	± 35°
Steering Relief Pressure	16 MPa

BRAKES	
Service Brake Type	Caliper dry disc
Service Brake Actuation	Air over hydraulic
Parking Brake Actuation	Mechanical apply; Hydraulic release

OPTIONAL EQUIPMENT	
Padfoot Drum Segment Kit (PDH)	
Rotary Beacon	
Backup Alarm	

TIRES	
Tire Size	20.5-25-16PR
Tire Pressure	300-330 MPa

HYDRAULIC SYSTEM	
Main Pump Type	Gear Pump
Main Relief Pressure	20 MPa

PERFORMANCE	
Static Linear Front Drum Load	322 N/cm
Number of Vibrating Drums	1
Nominal Amplitude Range	2.0 / 1.2 mm
Vibration Frequency Range	30 Hz
Centrifugal Force Range	280 / 170 kN
Number of Amplitude Settings	2

OPERATING MASS	
Operating Mass with Ballast	14,000 kg
Mass on Vibrating Drum	7,000 kg
Mass on Drive Axle	7,000 kg

SERVICE CAPACITIES	
Fuel Tank	200 L
Engine Oil	14 L
Cooling System	32 L

DIMENSIONS	
A Overall Length	6,000 mm
B Overall Width	2,280 mm
C Drum Width	2,130 mm
D Drum Diameter	1,555 mm
E Drum Thickness	30 mm
F Wheelbase	2,950 mm
G Min. Ground Clearance	450 mm
H Overall Height	3,050 mm

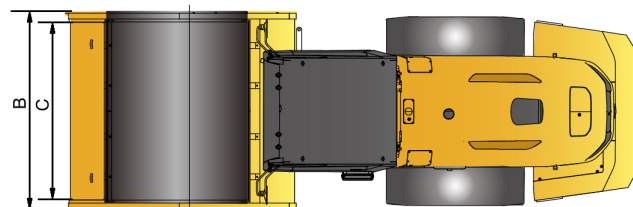
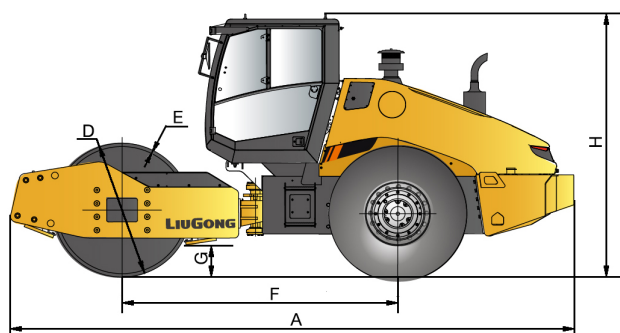

## Guangxi Liugong Machinery Co., Ltd.

No. 1 Liutai Road, Liuzhou, Guangxi 545007, PR China  
 T: +86 772 3886124 E: overseas@liugong.com  
 www.liugong.com

03/2018 Designed by Liugong

Specifications and designs are subject to change without notice. Machines shown may include optional equipment. Liugong standard and optional equipment may vary from region to region. Please consult your Liugong dealer for information specific to your area.